

# IMPERIAL SERIES

## 101S1/101S2/101S3

**MOSFi**

Registered with MSME (Govt. of India)  
 Powered by Alaska Automation Pvt. Ltd.  
 An ISO 9001:2015 Company

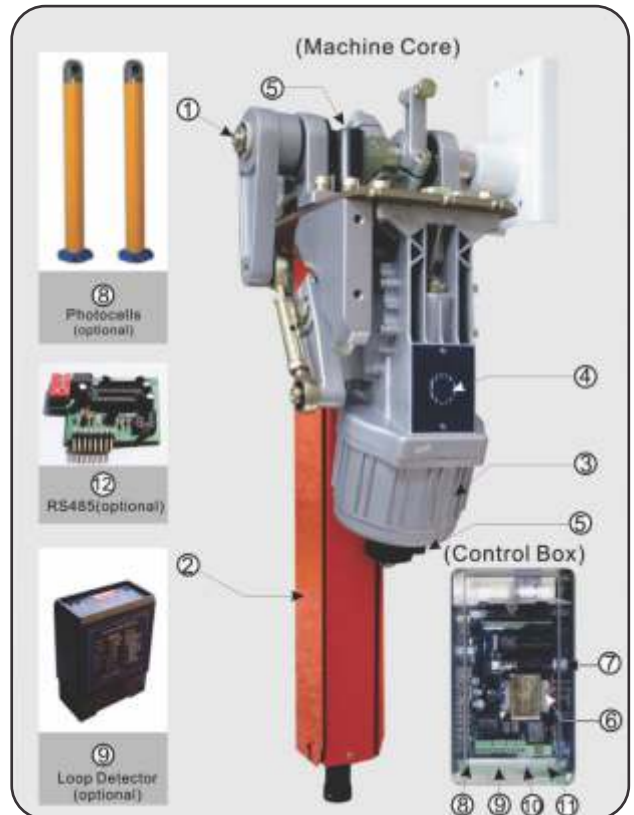
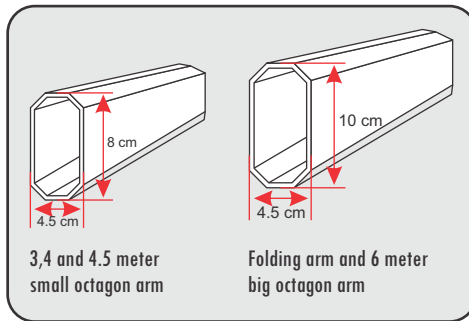
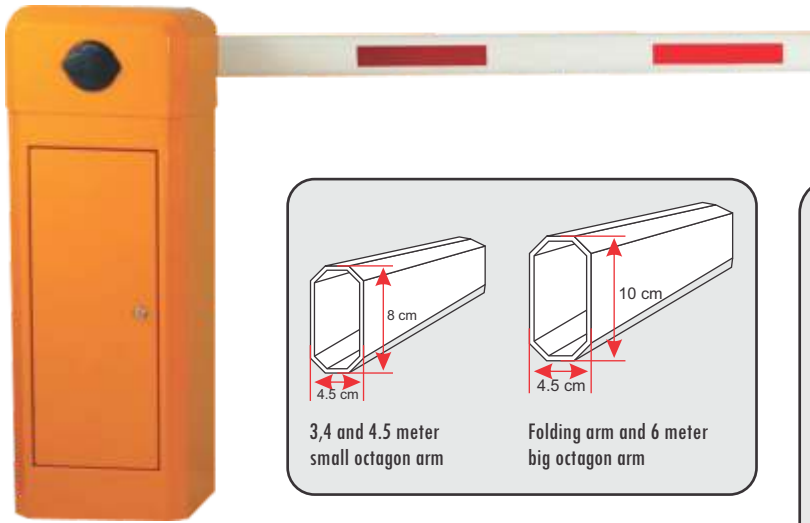

### Features :

- Manual release
- Die-casting aluminum alloy motor, precision and good at thermal radiating.
- Motor cooling fan, solving the problem of heat-protection.
- Auto-closing
- Support the infrared PHOTOCELL, VEHICLE LOOP DETECTOR
- Wire control (switch signal) Remote control (418MHz)
- RS485 Communication module (optional)

### Specification :

Model No. CHI	101S1	101S2	101S3	101F1	101F2	101F3	101F4	101DF	101TF
Max Boom Length	3m	4.5m	6m	3m	5m	3m	5m	4.5m	4m
Boom Type	Straight	Straight	Straight	Folding 90°	Folding 90°	Folding 180°	Folding 180°	Double Fence	Triple Fence
Operating Time	1sec	3sec	6sec	3sec	6sec	3sec	6sec	6sec	6sec
Boom Weight	3kg	4.5kg	6kg	6.5kg	8kg	9kg	11kg	7kg	7.5kg
Boom Dimension (WXH)	45X80mm	45X100mm							
Voltage	220V±10%, 110V±10%								
Frequency	50/60Hz								
Motor Voltage	220V								
Power	80W								
Working Temperature	-35°C~75°C								
Protection Grade	Ip44								